

SORTING GRAPPLE

P1 - P2 - P3 - P4

SORTING GRAPPLE

Sorting grapple with bidirectional hydraulic rotation as standard. P1 model has a rotating joint, while P2-P3-P4 models have a hydraulic rotation with slewing ring. They are made up of a high resistance frame. The grapple can be set up with side doors to increase its loading capacity.

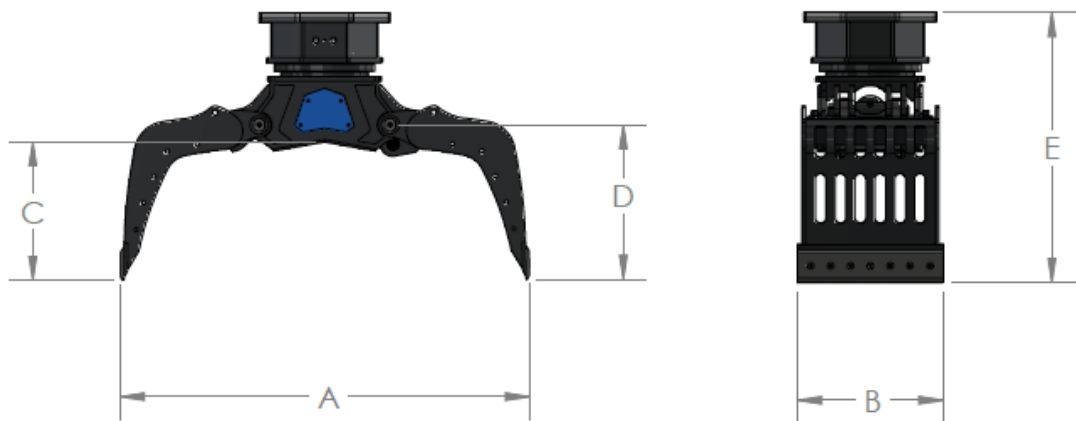

MODEL	P1	P2	P3	P4
MACHINES (ton)	1,5>3,0	4>8	11>14	14,1>15
ROTATION ANGLE	360°	360°	360°	360°
WEIGHT (Kg)	120	330	700	800
MAX CAPACITY (Lt.)	50	90	160	250
DIMENSION A (mm)	820	1430	1870	1870
DIMENSION B (mm)	340	500	660	900
DIMENSION C (mm)	280	480	620	620
FULCRUM DISTANCE (D)	310	560	710	710
HEIGHT (E)	720	1010	1210	1210
MAX PRESSURE CYLINDER (Bar)	220	250	250	250
CYLINDER FLOW RATE (L/min)	9	24	30	32
MAX ENGINE PRESSURE (Bar)	180	200	200	200
ENGINE FLOW RATE (L/min)	20	6	5	5